

When failure is not an option:
40 A Redundancy Module

SLR01

- Easy set-up of N+1 redundancies on the DIN-Rail
- Decoupling diode
- Ready relay contact
- For use with 24...28V power supplies up to max. 50A



Data sheet

Short description

When failures might cause costly extensive downtimes, a design solution is a redundant power supply that uses several (N+1) identical power supplies. The redundancy module SLR01 is designed to create an N+1 redundancy in combination with the PULS power supply SL40 or other 24...28V power supplies with an output current of up to 40A (max. 50A). One SLR01 is required for each power supply. The module decouples the output of the connected power supply from the others so that in the event of

failure one power supply unit cannot overload the other units. A relay-changeover contact, picked up under normal conditions and dropped in the event of failure, indicates the status of the connected power supply unit. A Dual Redundancy Module, SLR02, is available to provide redundancy with two attached power supply units, each with an output current of up to 30A (max. 35A). For smaller current values of 2.5A, 5A and 10A PULS also offers the SLR2, SLR5 and SLR10 power supplies with integrated redundancy modules.

Decoupling part

Voltage	
• nominal value	24 V DC
• max. rated	35 V, short-term 45 V
Voltage drop	
$V_{in} \rightarrow V_{out}$	typ. 0.6 V
Current per in- and output	
• nominal value	40 A
• max. rated	50 A
Protection against polarity reversal	yes
Connection	via stable screw terminals
• Connector size	solid: 0.5 - 16 mm ² flexible: 0.5-10 mm ² range
Note: The GND connector on the module exclusively serves as intrinsic power supply	

Construction/ Mechanics*

Housing dimensions and Weight	
• W x H x D	48 mm x 124 mm x 117 mm (+ DIN Rail)
• Free space for ventilation	above/below 10 mm recommended left/right 10 mm recommended
• Weight	646 g
Design advantages:	
• All connection blocks are easy to reach as mounted at the front panel	

*For further information see data sheets „The SilverLine“, „SilverLine Family Branches“

Order information

Order number	Description
SLR01	40A Redundancy Modul
SLZ01	(Screw mounting set, two needed per unit)

Relay contacts

Relay type	Changeover contact, picked-up during normal operation
• relay picks up („ok“)	when V_{in} between V_{low} and V_{high}
• relay drops out	when $V_{in} < V_{low}$ or $V_{in} > V_{high}$
Upper limit V_{high}	30 V \pm 5% fix
• hysteresis	appr. 0.7 V
Lower limit V_{low}	adjustable
• guaranteed range	16...27 V
• preset	22 V \pm 1%
• hysteresis	appr. 0.7 V
• relay delay	typ. 50 ms at undervoltage
Contact load	48 V DC / 1 A or 230 V AC / 0.5 A
Connection	via stable screw terminals
• connector size	solid: 0.5 - 6 mm ² flexible: 0.5-4 mm ² range
LEDs on the front panel	
• for input	green LED, when V_{in} between V_{low} and V_{high}
• for output	green LED, when $V_{out} >$ appr. 2.5...3.5 V
Note:	
• All relay contacts are potential-free	

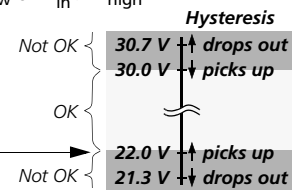

Further information

Test voltage	
• relay cont., V_{in} , V_{out}	3 kV
• relay contacts/PE	2.5 kV
• V_{in} , V_{out} /PE	500 V AC
Ambient temperature range T_{amb}	Operation: -10°C...+70°C Storage: -25°C...+85°C
Efficiency	> 97 %

Power wiring SLR01

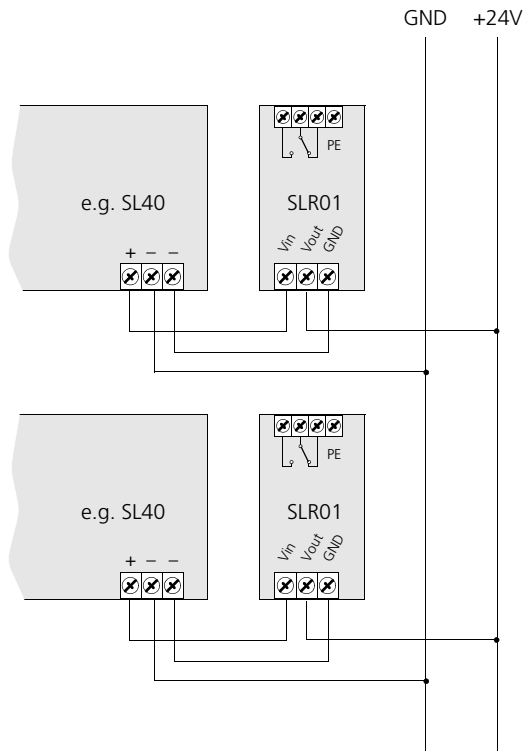

Bottom view SLR01

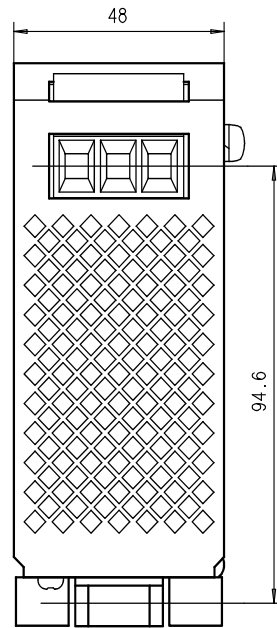

Side view SLR01

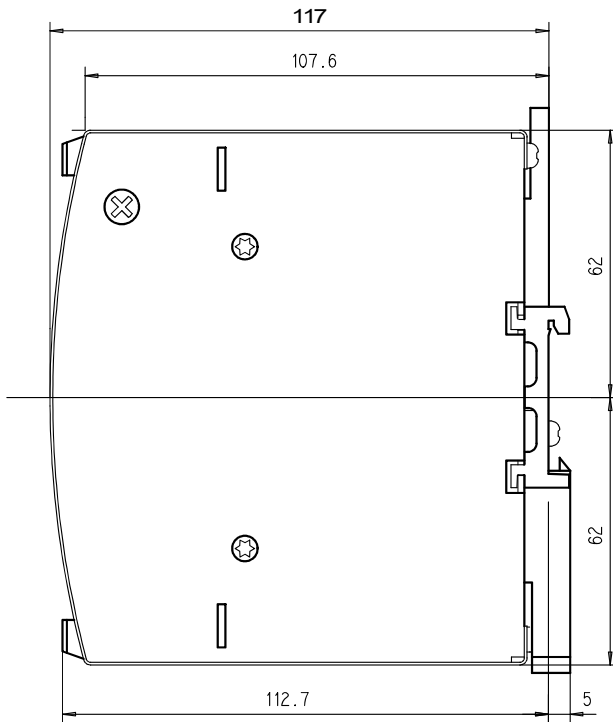

Front view SLR01

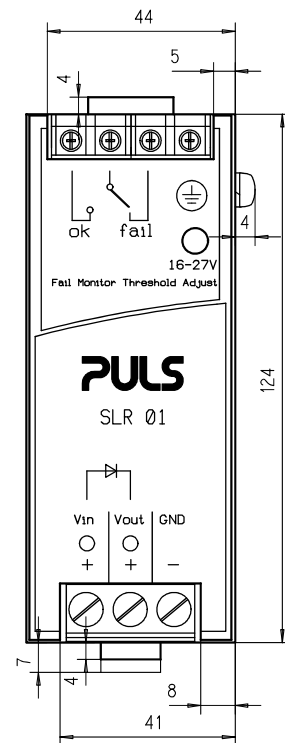

Further information, especially about EMC, Connections, Safety, Approvals, Mechanics and Mounting, see page 2 of „The SilverLine“ data sheet.

Unless otherwise stated, specifications are valid for AC 230V input voltage, +25°C ambient temperature, and 5 min. run-in time. They are subject to change without prior notice.